

Project:

Fixture Type:

Location:

Contact/Phone:

The LSKT424 is 4 inch Square Panel LED. This product's LED chip is at the edge. So it disperses light so that it is less dazzling and spreads evenly. The ultra-thin technology allows for extremely thin fixture depth. Also, the product can be installed quickly and easily without housing.

DESCRIPTION

- Aluminum body dissipates heat from the LED board.
- 4 different colors for trim White, Black, Bronze, Satin Nickel.
- Pre - installed spring loaded clips for easy installation with no need for a recessed housing.
- Cable connectors allow for easy connection between downlight module and driver junction box.

LED LIGHT ENGINE

- Protected LED driver performs at 120V
- Dimming down to 10% with most dimmers
- CCT 2700K, 3000K, 3500K, 4000K and 5000K available
- CRI ≥80 or ≥90
- Long life LED chips guaranteed up to 50,000hours.

WARRANTY

Guaranteed five years from the purchase date of the product, against mechanical defects in manufacturing.

LISTINGS

- cULus Listed / Type IC
- Energy star qualified
- Wet locations (Not suitable for coastal/salt water area)
- Damp locations
- RoHS compliances
- Tested in accordance with IESNA LM79 & LM80

PERFORMANCE DATA

Input Voltage	120V				
Input Power	10.5W				
Frequency	50 / 60Hz				
C R I	90				
T Ambient	-30 °C ~40 °C (-22 °F ~104 °F)				
C C T	2700 K	3000 K	3500 K	4000 K	5000 K
Lumens	670 lm	690 lm	710 lm	700 lm	670 lm

(all values at 25°C without a dimming control in circuit)

LSKT424

4" Square Panel LED



DIMENSIONS

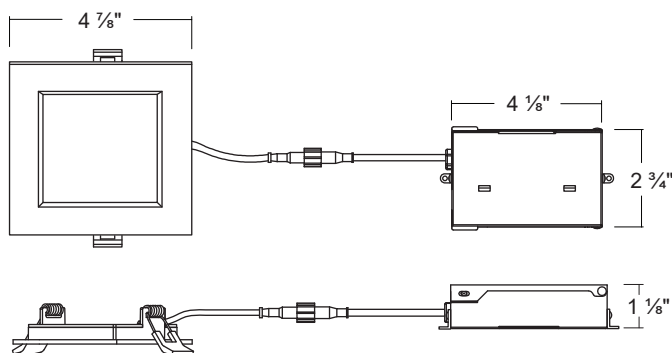

PRODUCT CODES

Model NO.	Description
LSKT424W	4" LED Square Panel / White
LSKT424B	4" LED Square Panel / Black
LSKT424SN	4" LED Square Panel / Satin Nickel
LSKT424BZ	4" LED Square Panel / Bronze

List of Triac Dimmer Switch

Mfr	Model #	Dimming Rate
COOPER	DLC03P	10 - 100%
Leviton	1A1505 / 1C1605	10 - 100%
Leviton	6631 / 6633	10 - 100%
Lutron	CT-603PG / CT-600PR	10 - 100%
Lutron	DV-600PR / DV603PG	10 - 100%
Lutron	DVW-603PGH / DVCL-153P	10 - 100%
Lutron	MACL-153M / TGCL-153P	10 - 100%
Lutron	S-600PR / S-2-LH	10 - 100%

Project: _____

Fixture Type: _____

Location: _____

Contact/Phone: _____

LSKT424

4" Square Panel LED



NEW CONSTRUCTION MOUNTING PLATE

Mounting Plate (without Hanger Bar)

LRP44
4" Mounting Plate / Square

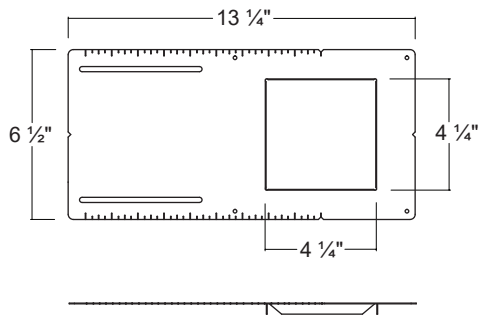

With Hanger Bar / without J-Box

LRPHB-64
Mounting Plate / Square /
for 2, 3, 4, 6 inch

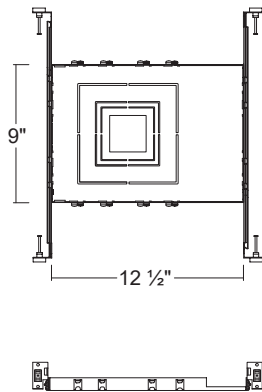

LRPHB-84
Mounting Plate / Square /
for 4, 6, 8 inch

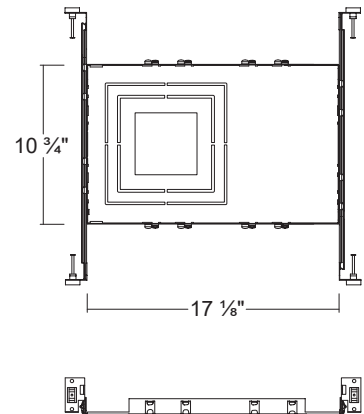

With Hanger Bar & J-Box

LRPJB-64
Mounting Plate / Square /
for 2, 3, 4, 6 inch

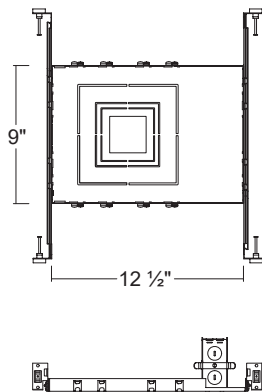

LRPJB-84
Mounting Plate / Square /
for 4, 6, 8 inch

